

# Instruction Manual

## Variable area flow meter Q-Flow

# Original Instruction Manual

## Variable area flow meter Q-Flow



Version: **qflow\_D5\_0**

Current information on our products can be found on the Internet at **[www.voegtlin.com](http://www.voegtlin.com)**

© 2019 Vögtlin GmbH, Switzerland

## Index

<b>Introduction</b>	<b>4</b>
Product description and intended use	4
Intended use	4
Safety Instructions	4
Copyright and privacy policy	5
Disclaimer	5
Warranty	5
Predictable risks	7
Corrosive Gases	8
Information on the type plate	9
Operating principle of the variable area flowmeter	10
Construction of the variable area flow meter Q-Flow	11
<b>Technical Information</b>	<b>11</b>
Technical data Q-Flow	11
Wetted Materials Q-Flow	12
Setups Q-Flow	12
<b>Measuring ranges air</b>	<b>14</b>
Notes on the configuration and specification of variable area flowmeters	15
Installation situations of variable area flowmeters	16
<b>Installation and commissioning</b>	<b>18</b>
Installation instructions	18
Instructions for commissioning	18
Recommended connections	18
<b>Disassembly and maintenance</b>	<b>19</b>
Important instructions	19
Disassembly variable area flowmeter Q-Flow	19
Panel mounting Q-Flow	20
Maintenance	21
Pollution	21
Cleaning	21
Return	21
<b>Appendix</b>	<b>22</b>
Dimensions Q-Flow	22
Contamination declaration	23

# Introduction

We are glad that you have decided to use our variable area flow meters. Our instruments will provide you with high-quality long-lived products.

These operating instructions provide you with important information for the planning and commissioning of your systems with regard to the safe use of variable area flowmeters. Please contact your distribution partner if anything is not clear.

We are committed to the continual improvement of our products and documentation. Your experience from everyday use can assist us with this. We welcome your comments and criticisms.

## Product description and intended use

The variable area flowmeters are purely mechanical measuring instruments and are used to measure and/or adjust a defined gas quantity. Below is a selection of common applications (no claim to completeness):

- Inerting in various processes (displacement of oxygen)
- Gas mixture adjustment during heat treatment
- Gas mixture adjustment for welding processes
- Oxygen input from fish transport container
- Setting a specific flow rate to a gas analyzer
- Adjusting the process gas in vacuum coating systems

## Intended use



The operator of the system is responsible for the safe operation of the control valves and takes precautions to avoid consequential damage in the event of a device defect (leakage). In particular, only materials which are resistant to the gas used may be used for corrosive gases. (See also notes on "corrosive gases" and "predictable risks").

## Safety Instructions



The variable area flowmeters have as measuring element a conical glass tube with a variable area which moves in it. If handled improperly, the measuring tube may break and gas may enter the environment. In the event of a leakage, the escaping gas can cause damage to the environment and/or personal injury. See also "Predictable risks" page 11.

## Copyright and privacy policy

We have prepared this operating manual with all due care. However, no responsibility is taken for the correctness, completeness and topicality of the contents.

This document is subject to copyright. Processing, in particular translation into another language, as well as distribution require the written consent of the manufacturer.

Data transmission via computer networks may be subject to security gaps. A complete protection of the data against access by third parties is therefore not possible.

## Disclaimer

The manufacturer is not liable for any damages whatsoever resulting from the use of this product. The operator is responsible for the correct installation, commissioning and safe operation of this product.

These products are warranted according to the current product information and the manufacturer's terms of sale and delivery.

The manufacturer reserves the right to change the contents of the documents, including this disclaimer, in any way and without notice. The manufacturer is not liable in any way for any consequences of such changes.

## Warranty

The warranty for the products described in this manual is limited to defects in material and workmanship. Warranty does in no case exceed product replacement free of charge. All claims are null and void in the case of improper use:



- Use outside operating limits
- Damage caused by pressure surges (see also "predictable risks")
- Corrosion damage caused by operation with gases which were not intended for this purpose at the origin, as well as by external influences.
- Mechanical damage in general

# Herstellereklärung Manufacturers Declaration

Bestätigung der Übereinstimmung  
mit den Anforderungen der europäischen  
Druckgeräterichtlinie 97/23/EG

confirming the correspondence with the  
requirements of the European Directive  
for pressure equipment 97/23/EC

## Vögtlin Instruments GmbH

erklärt, in alleiniger Verantwortung, dass  
die Produkte

declare on their own responsibility that  
the products

FLQ-\*  
FLV-\*  
FLM-\*

FLQ-\*  
FLV-\*  
FLM-\*

\*) etwaige Ausführungen

\*) various versions

Q-Flow Schwebekörper Durchflussmesser  
F-Flow Schwebekörper Durchflussmesser  
M-Flow Präzisions-Regelventile

Q-Flow variable area flowmeters  
F-Flow variable area flowmeters  
M-Flow precision control valves

mit den Bestimmungen der Druckgeräterichtlinie  
97/23/EG übereinstimmt.

Corresponds to the Pressure Equipment  
Directive 97/23/EC.

Angewandte Konformitätsbewertungsverfahren:

Applied conformity assessment procedures:

**Gute Ingenieur Praxis**

**Good engineering practice**

Es darf kein CE-Kennzeichen angebracht werden,  
siehe Artikel 3 Abs. 3 der Richtlinie 97/23/EG.

In acc.with Article 3 Paragraph (3) of the  
PED 97/23/EC the CE mark is not shown.

Aesch, 29.04.2016

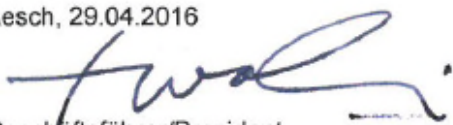
  
Geschäftsführer/President  
F. Waltz

  
Qualitätssicherung  
J.-P. Alder

## Predictable Risks



Before commissioning the system, the operator must take appropriate precautions to ensure that the environment and/or persons are protected in the event of a fault.

The safe operation of the measuring instruments must be taken into account in advance in the safety analysis.

### Leakage of the variable area flow meters can result in the following risks

- Escaping gas can be suffocating, toxic and/or corrosive. Please read the safety data sheet of the used gas or gas mixture from the respective gas supplier carefully beforehand.
- When flammable gases escape, an explosive gas mixture can form in the environment.
- In the case of aggressive media, leakage can lead to corrosion damage to the device and/or in the immediate vicinity.

### The following causes can lead to gas leakage:

- Solenoid valves are used upstream or downstream of the flow meter. When opened quickly, the float in the measuring glass shoots upwards and can lead to glass breakage. Please observe the recommendations under "Commissioning" when using solenoid valves.
- The maximum permissible operating pressure is exceeded. Take appropriate measures to ensure that the specified maximum pressure can never be exceeded
- The process connections are not tight due to improper installation. A leak test must be carried out before commissioning.
- The measuring instrument leaks because it is operated with a gas which was not intended for this purpose at the origin. As a result, gas may leak if the gaskets are not resistant to this gas.

The possible causes of gas leakage are not conclusive and may have other causes as well.

## Corrosive Gases



The operator is solely responsible for the safe operation of the system and takes precautions to protect the environment and/or persons in the event of leaks.

The instrument may only be operated with the gases for which the instrument has been designed and specified.

### Sealing materials for corrosive gases

The manufacturer shall propose the sealing material suitable for the specified gas. The data on resistance are taken from the literature of our suppliers. Therefore, we cannot take liability for the specified sealing material.

### Operation with ozone gas (O<sub>3</sub>)

The durability of the sealing material depends strongly on the operating conditions.

In ozone applications, concentration, humidity and temperature have a decisive influence on the resistance of the sealing material used.

Vögtlin Instruments only supplies a device for O<sub>3</sub> if the customer/plant operator himself determines the sealing material.

The same applies to unknown media and gas mixtures.





## Information on the type plate

The type plate on the Q-Flow is located on the back of the carrier plate and must not be removed.



### Example:

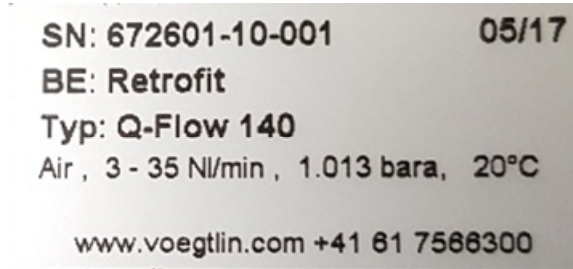

### Key:

- SN: Serial number
- BE: Order number or subject of the customer
- 05/17 Date of manufacture, month/year
- Typ: Specification according to type code (standard devices only)<sup>1</sup>

Medium, measuring range, unit, pressure, temperature & additional information

<sup>1</sup>Devices which are delivered according to customer-specific design are given a seven-digit article number (e.g. 137-1215) instead of the type code.

## Operating principle of the variable area flowmeter

The measuring instrument works according to the float measuring principle

The measuring unit consists of a tapered graduated precision glass measuring cylinder in which a ball float can move freely up and down. The medium flows through the vertically-aligned measuring cylinder from the bottom upwards

The float positions itself so that the *buoyancy force* **A** acting on it, the *form resistance* **W** and its *weight* **G** are in balance:

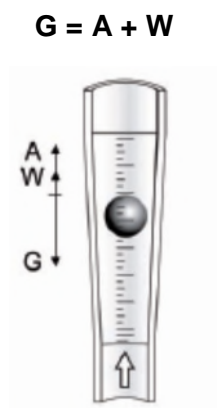

The flow rate can be read as the height of the float on a scale on the tapered measuring cylinder. The value is read off at the middle of the float (largest diameter).

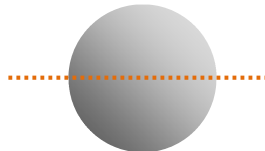

## Construction of the variable area flow meter Q-Flow

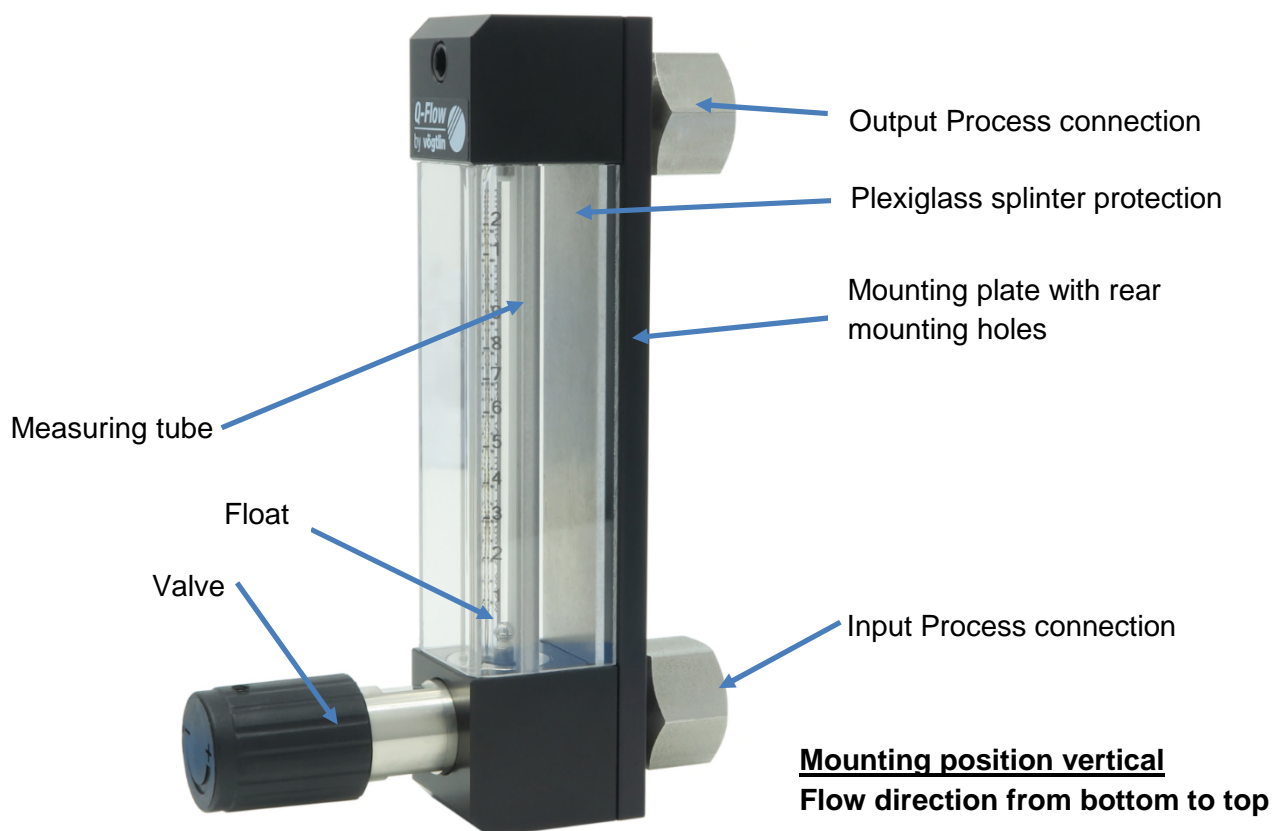

## Technical Information

### Technical data Q-Flow

Subject	Q-Flow 80	Q-Flow 140
Turndown ratio (min. / max.)	ca. 1:10	ca. 1:10
Accuracy in % of full scale	± 5 %	± 5 %
Measuring tube length	80 mm	140 mm
Scale length	65 mm	120 mm
Float	spherical	spherical
Pressure resistance	10 bar	10 bar
Max. pressure drop	100°C	100°C
Min. temperature	0°C	0°C

Note minimum temperature: At a gas temperature < 0°C, the outside of the measuring tube may mist up with ice and thus make reading more difficult.

## Wetted Materials Q-Flow

Component	Material Standard	Material optional
Top and base body	Anodized aluminum	SS 1.4305 (AISI 303)
Mounting plate	Anodized aluminum	
Measuring cylinder	Borosilicate glass	
Connections	SS 1.4305 (AISI 303)	
Float	SS 316 L / Glass / Ceramic	
Valve	Nickel-plated brass	SS 1.4305 (AISI 303)
Seals	FKM	EPDM / FFKM
Front cover / Splinter protection	Makrolon	
Shock absorbing limit stop	SS 1.4305 (AISI 303) / PTFE	

## Setups Q-Flow

(Process connection on the back side)



*With valve  
at inlet*



*With valve  
at outlet*



*Without valve*

# Variants of the valve rotary knobs

## Standard rotary knob

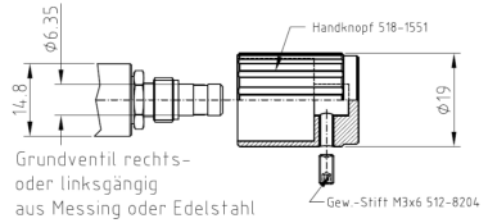

Grundventil rechts- oder linksgängig aus Messing oder Edelstahl

## Rotary knob with locking ring

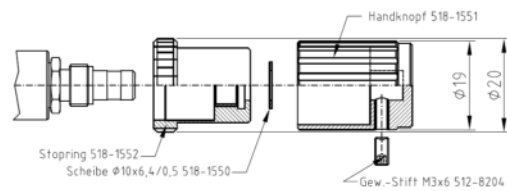

## Hexagon socket with lock nut (instead of rotary knob)

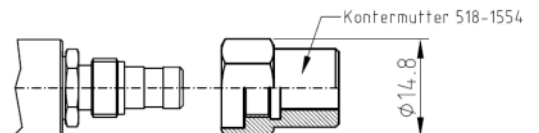
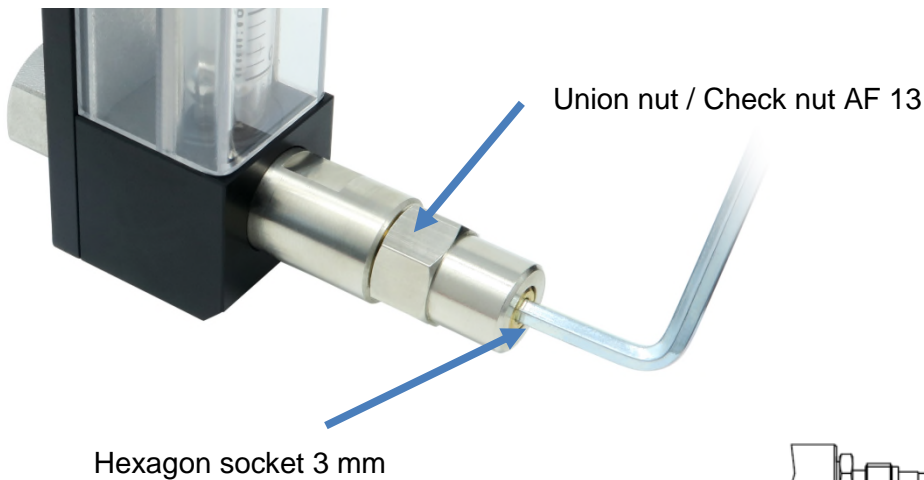

# Measuring ranges air



## Q-Flow 80 · Measuring ranges with direct reading scales · Alu/FKM · Connection G1/4" SL

Operating conditions: 20°C, 1013 mbar abs / Air	with valve*	without valve
0.2-1.5 l/min	Art.-N° 134-1233	Art.-N° 134-1248
0.3-2 l/min	Art.-N° 134-1234	Art.-N° 134-1249
0.5-4 l/min	Art.-N° 134-1235	Art.-N° 134-1250
1-7 l/min	Art.-N° 134-1236	Art.-N° 134-1251
1-15 l/min	Art.-N° 134-1238	Art.-N° 134-1253
2-24 l/min	Art.-N° 134-1239	Art.-N° 134-1254
4-32 l/min	Art.-N° 134-1240	Art.-N° 134-1255

## Q-Flow 140 · Measuring ranges with direct reading scales · Alu/FKM · Connection G1/4" SL

Operating conditions: 20°C, 1013 mbar abs / Air	with valve*	without valve
0.06-1.2 l/min	Art.-N° 134-1333	Art.-N° 134-1348
0.2-1.6 l/min	Art.-N° 134-1334	Art.-N° 134-1349
0.2-2.2 l/min	Art.-N° 134-1335	Art.-N° 134-1350
0.6-5.5 l/min	Art.-N° 134-1336	Art.-N° 134-1351
1-7 l/min	Art.-N° 134-1337	Art.-N° 134-1352
1.6-10 l/min	Art.-N° 134-1338	Art.-N° 134-1353
2-27 l/min	Art.-N° 134-1340	Art.-N° 134-1355
8-50 l/min	Art.-N° 134-1342	Art.-N° 134-1357

The unit ml/min or l/min always refers to standard conditions related to 0°C and 1013.25 mbar abs.  
 Accurate reading under operating conditions only (20°C and 1013.25 mbar abs (ambient pressure)).  
 Other pressures and temperatures must be corrected according to the below table.  
 Pressure min. 0.5 bar g (lower on request)  
 \*Valve at the inlet, standard rotary knob

## Conversion factors for alternating pressures and temperatures (pressure in the measuring tube)

Factors with measuring glasses calibrated to 20°C and 1013 mbar abs (operating conditions)

	0 bar g	1 bar g	2 bar g	3 bar g	4 bar g	5 bar g	6 bar g	7 bar g	8 bar g	9 bar g	10 bar g
0°C	1.035	1.45	1.78	2.06	2.30	2.52	2.72	2.91	3.08	3.25	3.41
10°C	1.017	1.43	1.75	2.02	2.26	2.47	2.67	2.86	3.03	3.19	3.35
20°C	1	1.41	1.72	1.99	2.22	2.43	2.63	2.81	2.98	3.14	3.29
30°C	0.983	1.38	1.69	1.95	2.18	2.39	2.59	2.76	2.93	3.09	3.23
40°C	0.967	1.36	1.66	1.92	2.15	2.35	2.54	2.72	2.88	3.04	3.18
50°C	0.95	1.33	1.63	1.89	2.11	2.31	2.50	2.67	2.83	2.98	3.13
60°C	0.934	1.31	1.61	1.86	2.07	2.27	2.46	2.62	2.78	2.93	3.07
70°C	0.918	1.29	1.58	1.82	2.04	2.23	2.41	2.58	2.74	2.88	3.02
80°C	0.903	1.27	1.55	1.79	2.00	2.19	2.37	2.54	2.69	2.84	2.97
90°C	0.887	1.25	1.53	1.76	1.97	2.16	2.33	2.49	2.64	2.79	2.92
100°C	0.872	1.23	1.50	1.73	1.94	2.12	2.29	2.45	2.60	2.74	2.87

The measured values refer to 0°C and 1013 mbar abs, according to DIN 1343.

## Conversion factors for other gases compared to air\*

Factors related to measuring glasses, which are designed for operating conditions of 20°C and 1013 mbar abs.

Gas type	Factor
N <sub>2</sub>	1.019
O <sub>2</sub>	0.944
Ar	0.85
CO <sub>2</sub>	0.84
He	1.25
H <sub>2</sub>	3.5
CH <sub>4</sub>	0.97
C <sub>3</sub> H <sub>8</sub>	0.88
N <sub>2</sub> O	0.84

\*Factors are indicative only.

## Conversion factors for other units\*

From	To	
	ml/min	l/min
sccm	1	0.001
cm <sup>3</sup> /min	1	0.001
l/min	1000	1
dm <sup>3</sup> /min	1000	1
l/h	16.67	0.0166
dm <sup>3</sup> /h	16.67	0.0166
m <sup>3</sup> /h	16670	16.67
CFM	28316	28.32
CFH	472	0.472

Technical specifications and/or dimensions are subject to change without notice.

## Notes on the configuration and specification of variable area flowmeters

When designing variable area flowmeters, misunderstandings often occur and, consequently, misuse in practice. We would be grateful if you would take a few minutes to read these instructions and complete the specification sheet.

### Pressure and temperature dependence

Variable area flowmeters are highly dependent on the temperature and [pressure in the measuring tube](#). So that we can design the "right" device for you, we need additional information from you.

Please select the appropriate installation situation 1-8 for your application from the following pages.

### Pressure conditions

For flow meters with integrated control valve, we need the differential pressure via the control valve so that the correct valve size (KV value) can be selected. Furthermore, the pressure in the measuring tube is decisive for a correct display.

### Control valve at input (see installation situations 3+4)

The most common application is operating mode 3. On the output side there is no or only a low back pressure (e.g. gassing of an open vessel or the influence of the pipeline). In this case, we determine 1 bar abs (ambient pressure) in the measuring tube. Even if the upstream pressure at the pressure reducer is now changed, the same flow can be expected at the same scale height.

### Control valve at outlet (see installation situations 5 to 7)

In the following operating modes, the valves are set to the output:

- Processes with changing back pressure. Here we recommend that you set the upstream pressure to at least twice the back pressure. This guarantees a constant flow even with unstable back pressure. However, it is important that the set pressure corresponds to the pressure marked on the scale or the pressure defined in the chart.
- During suction operation, ambient air is sucked through the flow controller with a vacuum pump. (e.g. for air samplers) The inlet is open to atmosphere. In this case we take 1 bar abs as a basis.

### Reference pressure and reference temperature

The volume indicated on the scale or in the chart always refers to 0°C and 1013 mbar abs (according to DIN 1343).

# Installation situations of variable area flowmeters

## Without control valve

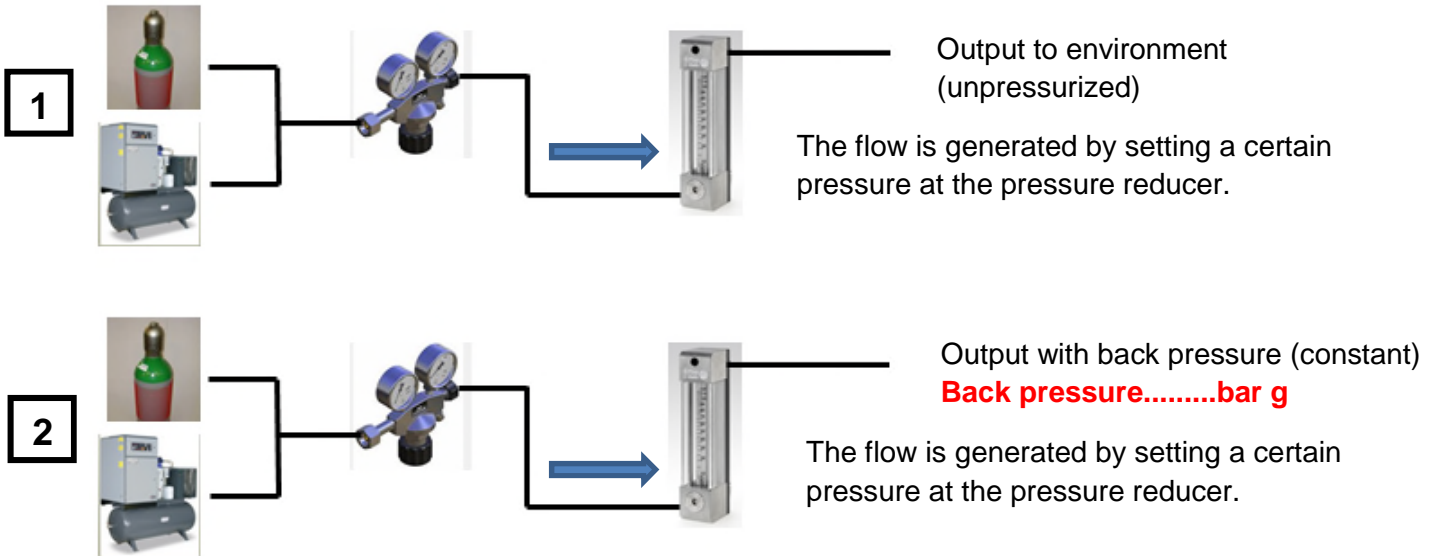

## With control valve **at the inlet**

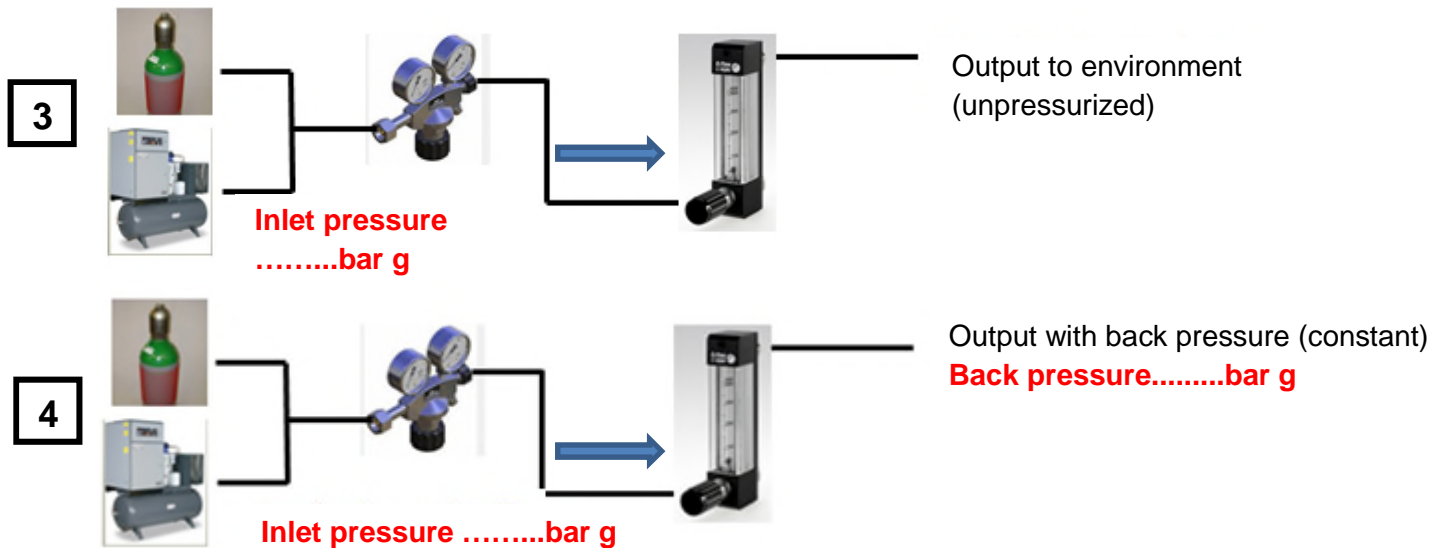



With control valve at outlet

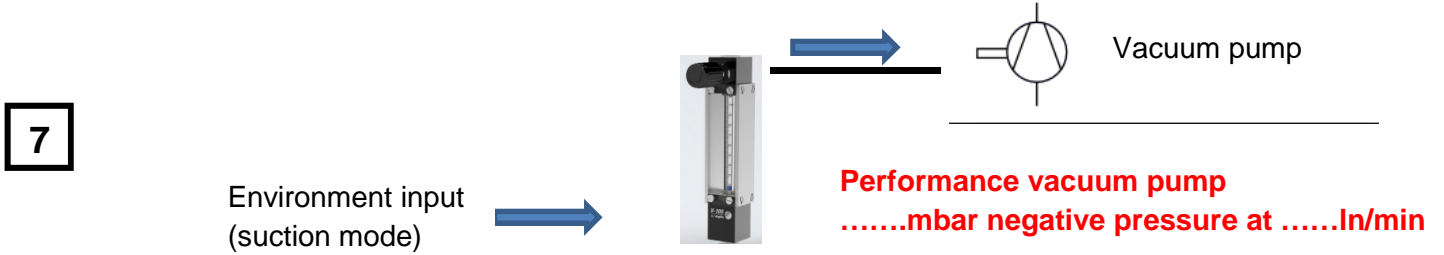
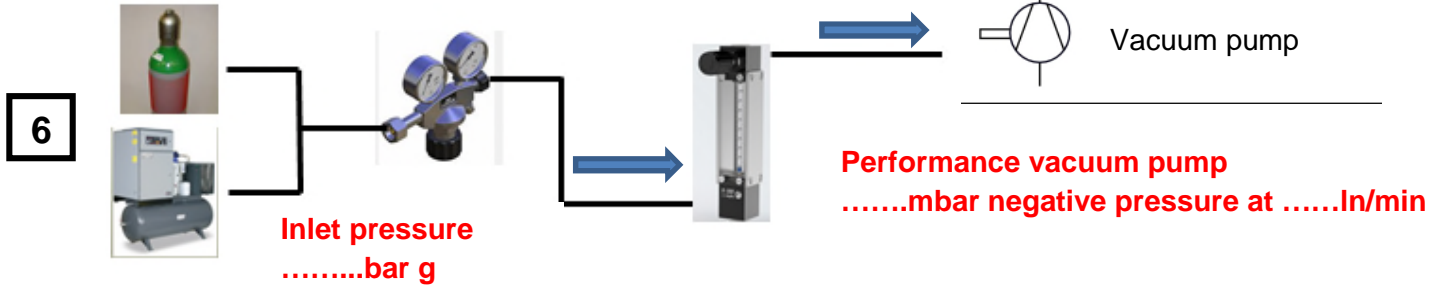
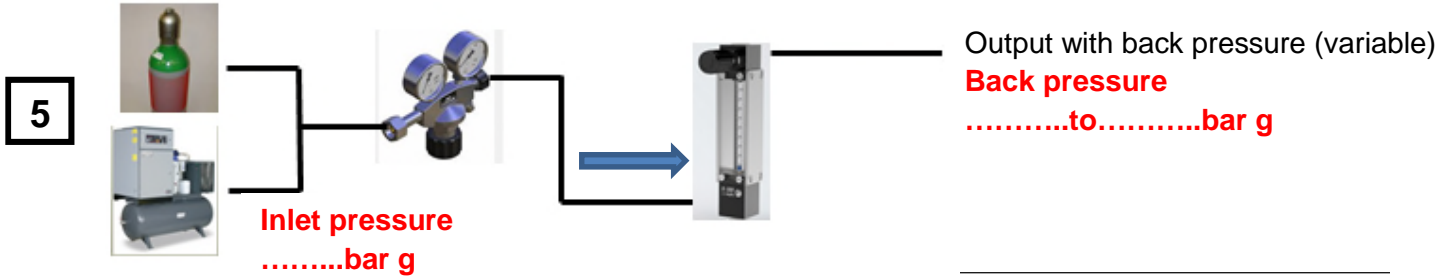

I cannot assign my measuring task to any situation  
Please sketch here

**8**

# Installation and commissioning



## Installation instructions

- The flowmeters may only be installed and commissioned by qualified personnel.
- The pipeline must be free of particles and moisture before installation of the measuring instrument. Please flush it before mounting the instrument in the pipe.
- The variable area flow meter must be installed vertically.
  - The direction of flow is from bottom to top.
- The measuring instrument must be mounted free of tension. Please use the provided mounting holes from bottom to top.
- The process connections must not be sealed with sealing tape or liquid sealant. Residues can get into the device and lead to malfunctions.  
(See also Recommended Connections section)
- Before commissioning, the connections and the measuring device must be checked for leaks.

## Instructions for commissioning

- The operating limits must not be exceeded  
(See section *Technical Information*)
- Connect the control valve to the flow meter or other control element
- Open the media supply
- Slowly open the control valve and set the required set value  
(See also section *Operating principle of the variable area flow meter*)
- If the use of solenoid valves cannot be avoided, we recommend keeping the pressure upstream of the measuring tube / needle valve as low as possible. This will reduce the risk of glass breakage caused by the float shooting up due to a pressure shock.

## Recommended connections

We recommend that you only use process connections that seal with an O-ring or a suitable sealing ring. For example:



Compression fitting for metal tubing

Hose nozzles for soft hose

Hose push-in connectors for hose

# Disassembly and maintenance

## Important instructions



- Please close the gas supply, flush the pipes and then close any shut-off valves. Make sure that the line is depressurized and that no dangerous gas can enter the environment. You can then start removing the meter. Only use suitable tools for this purpose. The removal and installation of the measuring instruments may only be carried out by qualified personnel.



## Disassembly variable area flowmeter Q-Flow

- Remove the Plexiglas cover (1) from the instrument
- Unscrew the valve (2) using an open-end wrench and remove it carefully from the instrument with a twisting motion
- Unscrew the cap screw (3) (hexagon socket, key size 4 mm)
- Pull the instrument off the mounting plate
  - The mounting plate can remain connected to the pipeline and does not need to be removed.
- Replace the new or repaired fitting and assemble the device in reverse order.
- Please carry out a leak test after completion of the installation and only start up the system if no leak has been detected.

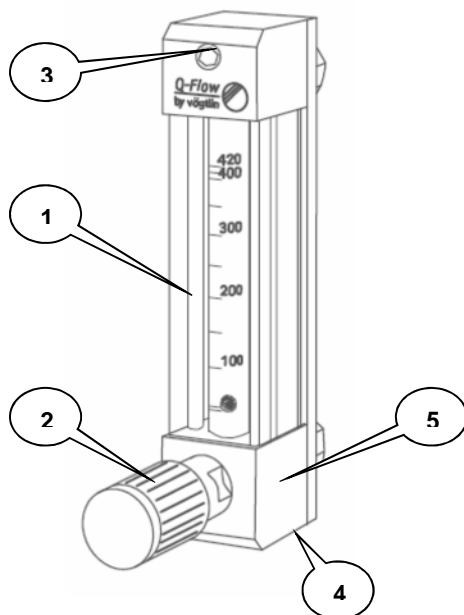



## Panel mounting Q-Flow

- For mounting, the panel opening must be prepared according to the diagram.
- Screw the two mounting brackets onto the instrument as shown.
- Screw the setscrew supplied into the connector and insert the instrument into the aperture from the front.
- From the other side, hang the connectors in the openings of the mounting brackets.
- The instrument can be secured by careful tightening of the setscrews.

### Panel aperture:

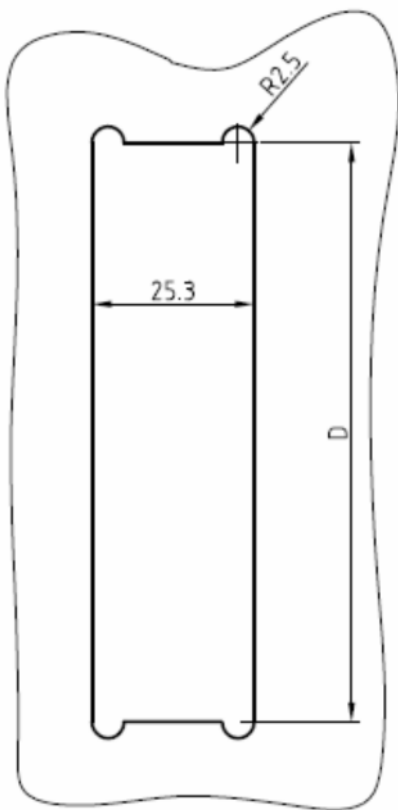

Dimensions in mm

Typ	Mass D
Q-Flow 80	129.3
Q-Flow 140	189.3

### Mounting-Kit:

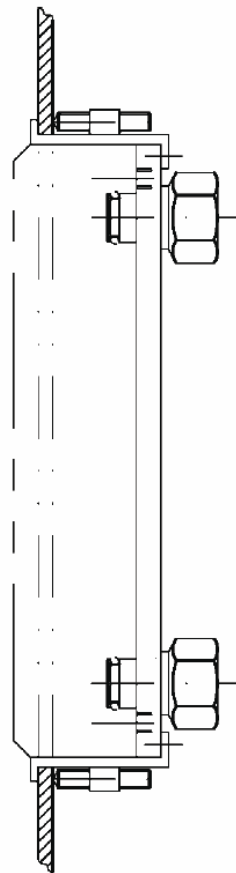

## Maintenance

When used correctly, variable area flow meters from Vögtlin Instruments AG do not require any maintenance.

## Pollution

The following symptoms indicate pollution:

- The set value can no longer be reached – the control valve is probably soiled
- The measured value increases although the effective flow rate has not been changed - measuring tube is dirty.
- Color change / deposits in the measuring tube

## Cleaning

Depending on the type of contamination, the meter can be rinsed with isopropyl alcohol (IPA). If necessary, the measuring tube can be cleaned mechanically with a brush.

**If soiled, we recommend that you return the measuring instrument to your distribution partner.**

## Return

When returning, please use the original packaging if possible or suitable alternative packaging. We do not accept responsibility for damage in transit. Please inform us of the reason for return: this enables us to process your request quickly

### Note

 If the instrument has been in contact with corrosive or toxic media it is imperative to clean it properly before return. Please always complete the contamination declaration form. This is provided in the appendix to this manual.

Instruments which we receive without a contamination declaration form will unfortunately have to be returned to the sender.

# Appendix



## Dimensions Q-Flow

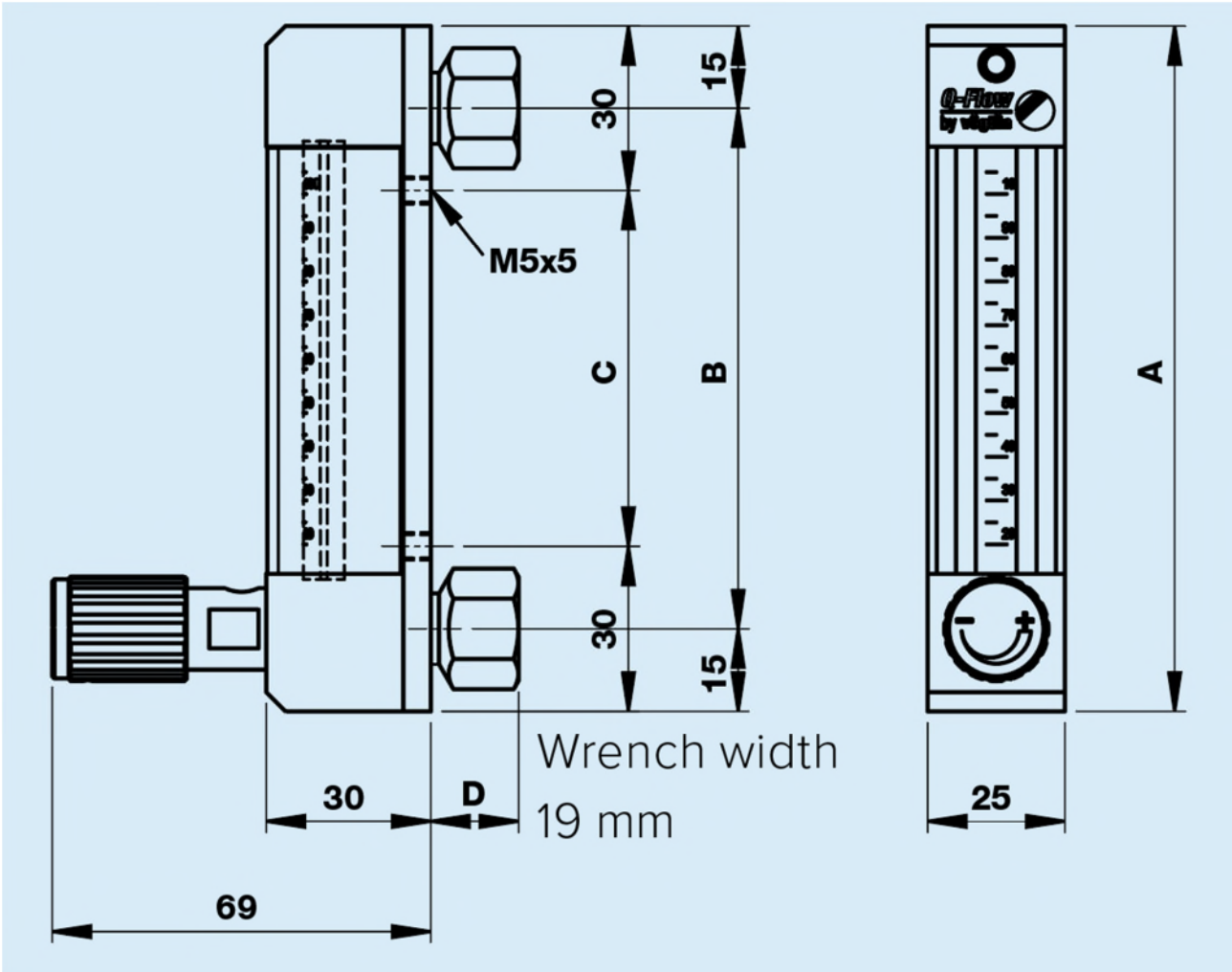

Type	A	B	C
<b>Q-Flow 80</b>	125	95	65
<b>Q-Flow 140</b>	185	155	125

Fittings	D	Thread depth
G1/4" female for compression fittings	17	12

## Contamination declaration

With return of devices, please fill out the following statement completely, especially the reason for the return, the type of residue and cleaning in the case of soiling, as well as indication of hazards.

<b>Device:</b>
Type code: _____
Serial number: _____

<b>Reason for return:</b>

<b>Type of contamination</b>
Device came in contact with: _____
Cleaned by us with: _____

<b>Can you provide further information on the contamination?</b>	<input type="radio"/> inert (no danger)
	<input type="radio"/> corrosive
	<input type="radio"/> caustic
	<input type="radio"/> must not come in contact with moisture
	<input type="radio"/> oxidizing
	<input type="radio"/> other hazards:

For the protection of our employees and for general safety during transport, proper cleaning and the use of appropriate packaging are mandatory.

<b>Legal declaration</b>
We hereby confirm the correctness and completeness of the above information:
<b>Company:</b> _____
<b>Address:</b> _____
<b>Phone:</b> _____
<b>Contact person:</b> _____
<b>Date:</b> _____
<b>Signature:</b> _____

## Change log

<b>Date</b>	<b>Version</b>	<b>Replaces</b>	<b>Author</b>	<b>Note</b>
01.03.2010	vflow_D4_3	vflow_D4_2	MHU	Page 21 / New Article Code
17.01.2011	vflow_D4_4	vflow_D4_3	MHU	Page 9, 10: Material of limit stop added
07.05.2012	vflow_D4_5	vflow_D4_4	LEU	Page 18 / Sealing Material
02.04.2014	vflow_D4_6	vflow_D4_5	LEU	Page 31 / Drawing
22.04.2014	vflow_D4_7	vflow_D4_6	LEU	Page 11 / Drawing
27.06.2019	qflow_D4_8	Vflow_D4_7	JER	General overhaul according to "Retrofit"
08.07.2019	qflow_D5_0	qflow_D4_8	MHU	Adaption Layout
10.10.2019	qflow_D5_0	qflow_D4_9	FLU	Various correction according to "Retrofit"