

NEMA 6 / IP67 Compliant Industrial Mass Flow Meters and Controllers For Gases

- Industry's only NEMA 6/IP67 industrial MFC affords wash down protection eliminating the need for secondary enclosures
- Measure & Control gas mass flow rates up to 1000 SLPM (other Sierra mass flow meters available up to 100,000 SLPM & higher)
- Accuracy: +/-1.0% of Full Scale
- Repeatability: +/- 0.2% Full Scale ensures a stable process even under changing conditions
- Dial-A-Gas® lets you select from up to 10 gases in one instrument, creating great flexibility and reducing spares inventory
- Operation at low differential pressures possible due to powerful direct valve design
- Both digital and analog communication included
- View and change the following functions in the field via RS-232:
 - Gas
 - Setpoint Value
 - Setpoint source
 - Engineering units
 - Output signal
 - Valve state
 - Full scale value
 - Password
 - 316 stainless steel construction is suitable for any clean gas, even corrosives & toxics
- Single sided power (24 VDC) reduces installation cost
- Modbus RTU Digital Protocol

MaxTrak 180



DESCRIPTION

MaxTrak™ is an industrial mass flow controller from the company that has been a trusted name in industrial thermal mass flow meters for decades—Sierra Instruments.

In applications where frequent wash-down / hose-down is required, such as food and beverage, chemical processing, pharmaceutical and biotech, MaxTrak™ outperforms the competition as it conforms to the rigorous requirements of NEMA 6 and IP67.

Excellent accuracy and reliability coupled with unsurpassed instrument stability result from a patented, inherently linear design, advanced platinum sensor technology and a valve that is strong and forgiving of variations in process conditions.

Max-Trak™ measures and controls gas mass flow from 10 to 1000 SLPM, with lower flows (to 2 SLPM) and higher flows available upon request. Based upon Sierra's successful SmartTrak® line of digital instruments, MaxTrak™ also offers Dial-A-Gas® multi-gas capability, both analog and digital communication and a wide variety of field adjustable parameters.

MaxTrak™ delivers the performance, flexibility and value you expect from Sierra Instruments.



www.sierrainstruments.com



PERFORMANCE SPECIFICATIONS

Accuracy

Standard: +/- 1.0% of full scale including linearity under calibration conditions
 (+/- 2.0% of full scale for 180M from 201 to 300 slpm)
 High Accuracy Calibration: +/-0.5% of reading + 0.3% of full scale at calibration conditions

Dial-A-Gas

+/- 1.0% of full scale in all 10 standard gases

Repeatability

+/- 0.2% of full scale

Temperature Coefficient

+/- 0.025% of full scale per °F (0.05% of full scale per °C), or better

Pressure Coefficient

+/- 0.01% of full scale per psi (0.15% of full scale per bar), or better

Response Time

300 millisecond time constant; 2 seconds typical to within +/-2% of final value (includes settling time). Faster or slower available upon request.

OPERATION SPECIFICATIONS

Gases

Measures and controls all clean gases including corrosives and toxics; specify when ordering.
 The following ten gases make the Dial-A-Gas® feature of every SmartTrak instrument; up to nine alternate gases may be substituted.

TABLE 1: Dial-A-Gas		
Flow Rate (slpm)	Maximum Flow Rate Standard Size (slpm)	Maximum Flow Rate High Flow Size (slpm)
Air	300	1000
Argon	435	1450
CO2	220	740
CO	302	1000
Methane	227	720
Helium	420	1454
Hydrogen	300	1000
Oxygen	300	1000
Nitrogen	300	1000
Nitrous Oxide (N2O)	215	710

Mass Flow Rates

180M Medium Flow Size: 0-10 to 0-200 slpm full scale
 180H High Flow Size: 0-100 to 0-1000 slpm full scale
 Flow range specified is for an equivalent flow of nitrogen at 760 mm Hg and 21°C (70°F); other ranges in other units are available (e.g., nlpm, scfh, NM³/H, kg/H)

Gas Pressure

500 psig (34.5 barg) maximum, burst tested to 750 psig (52 barg)

Gas & Ambient Temperature

Gas: 32°F to 122°F (0°C to 50°C)
 Ambient: -5 to 122°F (-20 to 50°C)

Leak Integrity

5 X 10⁻⁹ atm. cc/sec of helium maximum

Power Requirements (ripple should not exceed 100 mV peak-to-peak)

For All Mass Flow Meters: 15-24 VDC +/- 10%, (130 mA, regulated).

For Mass Flow Controllers:
 C180M: 24 VDC +/- 10%, (700 mA, regulated)
 C180H: 24 VDC +/- 10%, (1260 mA, regulated)

Control Range For Controllers

2 to 100% of full scale flow; automatic shut-off at 1.9 %

Output Signal

Analog:
 Linear 4 to 20 mA, 500 ohms maximum loop resistance and one of the following (user selectable):
 Linear 0 to 5 VDC, 1000 ohms minimum load resistance
 Linear 0 to 10 VDC, 1000 ohms minimum load resistance
 Linear 1 to 5 VDC, 1000 ohms minimum load resistance
 Digital:
 RS-232
 Modbus RTU

Command Signal

Analog (choice of one, user selectable):
 Linear 4–20 mA
 Linear 0–5 VDC
 Linear 0-10 VDC
 Linear 1-5 VDC
 Digital:
 RS-232
 Pilot Module Display or RS-485 optional

Physical Specifications

Wetted Material
 316 stainless steel; 416 stainless steel; Viton® "O"-rings and valve seat standard
 Other elastomers are available (consult factory).



©Dial-A Gas is a registered trademark of Sierra Instruments, © Nylon, Viton, Neoprene, Kalrez are registered trademarks of DuPont.

OPERATION SPECIFICATIONS

Pressure Drop Across a Meter

Pressure must be above the values in the table below. Note that pressure increases with flow rate.

MINIMUM DIFFERENTIAL PRESSURE FOR AIR IN PSI (MBAR), METERS			
Flow Rate (slpm)	Standard Size (M180M) 3/8 or 1/2 inch fittings	High Flow Size Small Bore (M180H) (std up to 500 slpm) 1/2 comp fittings	High Flow Size Large Bore (M180H1, H2) (std 501 to 1000 slpm) 3/4 comp fittings
10	0.5 (34)	N/A	N/A
20	0.5 (34)	N/A	N/A
30	0.5 (34)	N/A	N/A
40	0.5 (34)	N/A	N/A
50	0.5 (34)	N/A	N/A
100	1.0 (68)	1.0 (68)	0.5 (34)
150	2.0 (136)	1.2 (81.6)	0.5 (34)
200	5.5 (374)	1.5 (102)	0.5 (34)
250	N/A	1.8 (122.4)	0.5 (34)
300	N/A	2 (136)	0.6 (408)
350	N/A	2.5 (170)	0.7 (476)
400	N/A	3 (204)	0.9 (612)
450	N/A	3.5 (238)	1.1 (748)
500	N/A	4 (272)	1.3 (884)
750	N/A	N/A	3.0 (204)
1000	N/A	N/A	5.0 (340)

Differential Pressure Requirement for Controllers (lower or higher available upon request)

Optimum: 30 to 60 psi (2 to 4 bar)

Minimum: See chart below. Note that required pressure increases with flow rate.

MINIMUM DIFFERENTIAL PRESSURE FOR AIR IN PSI (MBAR), CONTROLLERS			
Flow Rate (slpm)	Standard Size (C180M) 3/8 or 1/2 inch fittings	High Flow Size Small Bore (M180H) (std up to 500 slpm) 1/2 comp fittings	High Flow Size Large Bore (M180H1, H2) (std 501 to 1000 slpm) 3/4 comp fittings
10	N/A	N/A	N/A
20	1 (68)	N/A	N/A
30	1.2 (82)	N/A	N/A
40	1.6 (110)	N/A	N/A
50	2 (136)	N/A	N/A
100	5 (340)	1.5 (102)	1.0 (68)
150	10 (680)	2 (136)	1.0 (68)
200	15 (1020)	4.5 (306)	1.0 (68)
250	20 (1360)	5.5 (374)	1.5 (102)
300	25 (1700)	6.5 (442)	2.0 (136)
350	N/A	8.5 (578)	3.0 (204)
400	N/A	10.5 (714)	4.0 (272)
450	N/A	13 (884)	5.0 (340)
500	N/A	15 (1020)	6.0 (408)
750	N/A	N/A	15 (1020)
1000	N/A	N/A	20 (1360)

All dimensions are in inches with mm in brackets. Certified drawings are available on request.

M180M, M1 and C180M, M1 Front View

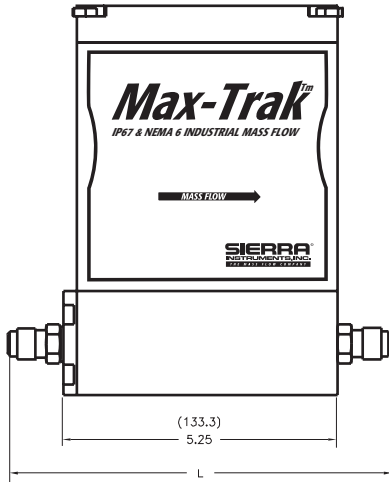

M180M, M1 and C180M, M1 Side View

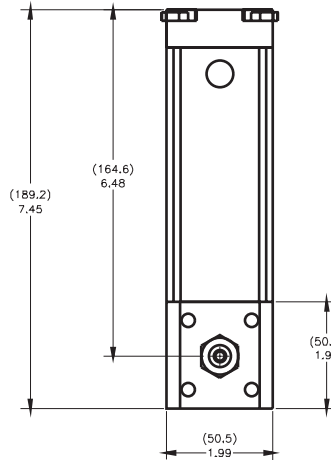

M180M, M1 and C180M, M1 Bottom View

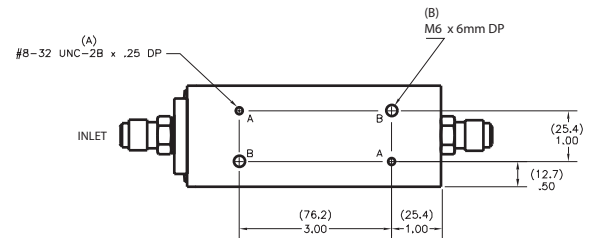

DIMENSION L

Fittings	Length with fittings in inches (mm)				
Flow Rate (slpm)	C180/M180M	M180H	M180H1, H2	C180H	C180H1, H2
1/8 compression	N/A	N/A	N/A	N/A	N/A
1/4 compression	7.27 (186)	N/A	N/A	N/A	N/A
3/8 compression	7.39 (189)	N/A	N/A	N/A	N/A
1/2 compression	7.55 (194)	8.92 (229)	N/A	10.37 (266)	N/A
1/4 VCO	6.81 (175)	N/A	N/A	N/A	N/A
3/4 VCO	7.25 (186)	8.56 (220)	N/A	10.01 (267)	N/A
1/4 VCR	N/A	N/A	8.78 (225)	N/A	11.28 (289)
1/2 VCR	7.13 (183)	N/A	N/A	N/A	N/A
6 mm compression	7.43 (191)	9.00 (231)	N/A	10.45 (268)	N/A
10 mm compression	7.63 (196)	N/A	N/A	N/A	N/A
12 mm compression	7.10 (182)	N/A	N/A	10.35 (265)	N/A
1/4 FNPT	7.25 (186)	8.90 (228)	N/A	N/A	N/A
3/8 FNPT	N/A	N/A	N/A	N/A	N/A
1/2 FNPT	N/A	N/A	N/A	10.59 (272)	N/A
3/4 FNPT	N/A	9.14 (234)	9.30 (238)	N/A	11.30 (290)
3/4 compression	N/A	N/A	9.18 (235)	10.69 (274)	11.68 (300)
1 inch compression	N/A	N/A	9.52 (244)	N/A	12.02 (308)

All dimensions are in inches with [mm] in brackets. Certified drawings are available on request.

M180H, H1, H2 Front View

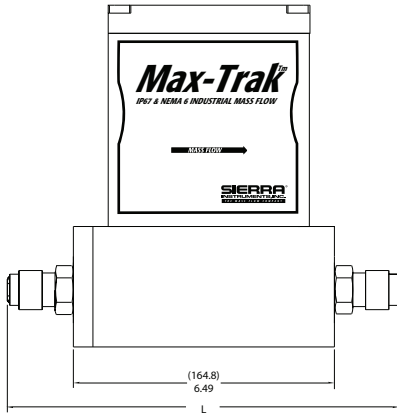

M180H, H1, H2 Side View

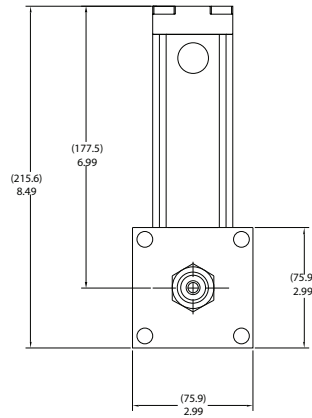

M180H, H1, H2 Bottom View

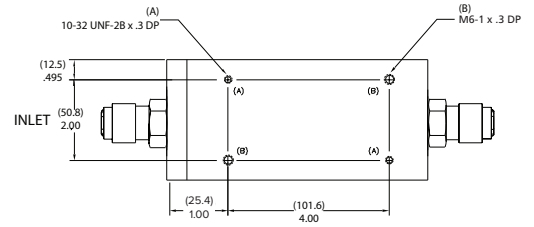

C180H, H1, H2 Front View

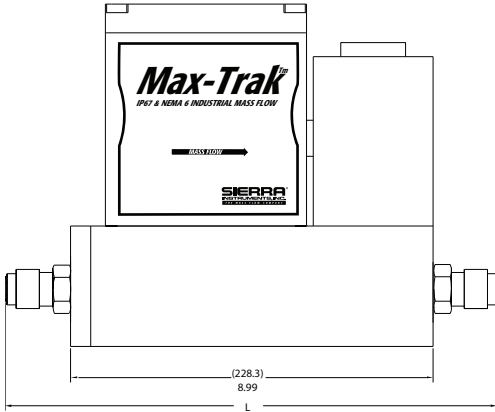

C180H, H1, H2 Side View

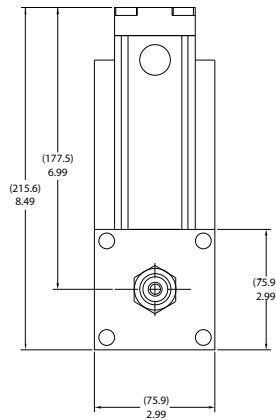

C180H, H1, H2 Bottom View

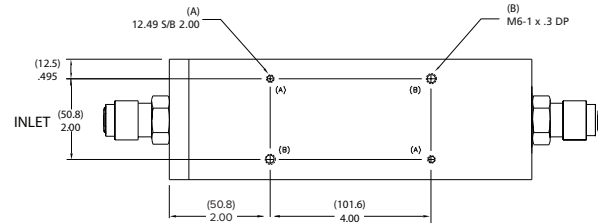

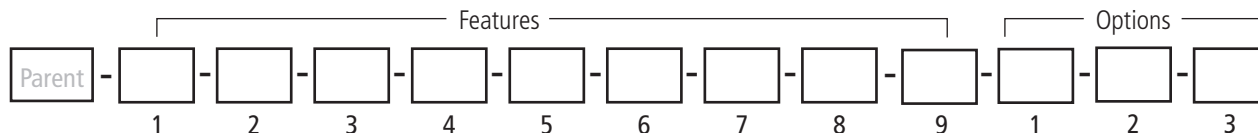

Instructions: To order a 180 please fill in each number block by selecting the codes from the corresponding features below and following pages.

Parent Number	
M180	NEMA 6 / IP67 Compliant Industrial Mass Flow Meter, digital high performance with Dial-A-Gas®
C180	NEMA 6 / IP67 Compliant Industrial Mass Flow Controller, digital high performance with Dial-A-Gas

Feature 1: Flow Body Size*			
M180M	Standard NEMA 6 flow meter. 0-10 slpm up to 0-200 slpm	C180M	Standard NEMA 6 flow controller. 0-10 slpm up to 0-200 slpm
M180H	High flow NEMA 6 meter. 0-100 to 0-500 slpm full scale	C180H	High flow NEMA 6 controller. 0-100 to 0-500 slpm full scale
M180H1	High flow NEMA 6 meter. 0-501 to 0-800 slpm.	C180H1	High flow NEMA 6 controller. 0-501 to 0-800 slpm.
M180H2	High flow NEMA 6 meter. 0-801 to 0-1000 slpm.	C180H2	High flow NEMA 6 controller. 0-801 to 0-1000 slpm.

Note: All slpm flow ranges also available in nlpm
 * Flow bodies are sized for nitrogen flow rates. Other gases must be converted to equivalent nitrogen flow. Use K-Factor and size accordingly.

Feature 3: Inlet / Outlet Fittings			
3	3/8-inch compression (standard for 30 to 300 slpm). For low and medium bodies. (maximum 300 slpm)	11	10 mm compression. For low and medium bodies. (maximum 300 slpm)
4	1/2-inch compression For all flow bodies up to 500 slpm. Above 500 slpm contact factory	12	12 mm compression. For all flow bodies up to 500 slpm. Above 500 slpm contact factory
5	1/4-inch VCO. For low flow bodies only. (maximum 50 slpm)	13	1/4-FNPT adapter bushing (maximum 200 slpm). For low and med flow bodies only
6	1/2-inch VCO. For low and medium flow bodies	14	3/8 FNPT. For low and med flow bodies only
7	3/4-inch VCO. For H1 and H2 high flow bodies only	15	1/2 -FNPT. For medium and high flow bodies up to 500 slpm.
8	1/4-inch VCR. For low flow bodies only. (maximum 50 slpm)	16	3/4-FNPT. For H and H1 high flow bodies only.
9	1/2-inch VCR. For all flow bodies up to 500 slpm. Above 500 slpm contact factory.	17	3/4-inch compression. For Hand H1 flow bodies only.
10	6 mm compression. For low flow bodies. (maximum 50 slpm)	18	1-inch compression. For H2 high flow bodies only.

Feature 5: Valve Seat (MFC only)			
SV1	Viton®	SK2	Kalrez® (or equivalent for high flow bodies)
SN1	Neoprene® (or equivalent)	PA1	ValFlex™ inert, carbon-reinforced Polyamide required for CO2 above 50% concentration or 250 psi
SK1	Kalrez® (or equivalent)		

Feature 2: Pilot Module Display	
NR	No display available
MB	RS-485 communication featuring Modbus protocol installed inside the enclosure

Feature 3A: Flanges for H1 and H2 only	
F2	1/2-inch ANSI class 150 flange, 316L
F3	3/4-inch ANSI class 150 flange, 316L
F4	1-inch ANSI class 150 flange, 316L
G2	1/2-inch ANSI class 300 flange, 316L
G3	3/4-inch ANSI class 300 flange, 316L
G4	1-inch ANSI class 300 flange, 316L
FD3	DN20/PN16 flange, 316L
FD4	DN25PN16 flange, 316L
GD3	DN20/PN40 flange, 316L
GD4	DN25PN40 flange, 316L

Feature 4: Flow Body Elastomers	
OV1	Viton® (Standard). Note: Consult factory for other elastomers
ON1	Neoprene®

Feature 6: Input Power	
PV2	24 VDC for all instruments (standard)

Feature 7: Output Signal	
V1	0-5 VDC and 4-20 mA linear output signals
V2	1-5 VDC and 4-20 mA linear output signals
V3	0-10 VDC and 4-20 mA linear output signals

Note: Alternate among V1, V2, V3 with Pilot Module display/interface or Smart-Trak Software

Feature 8: External Setpoint Signal (MFC only)			
S0	Pilot Module/RS-232 (standard for Pilot Module/digital operation)	S3	0-10 VDC , linear
S1	0-5 VDC, linear, standard for analog operation	S4	4-20 mA , linear
S2	1-5 VDC, linear		

Feature 9: Electrical Connection	
COND	1/2-inch FNPT port for conduit (standard) NOTE: Customer must supply own cable.
GLAND	Cable gland (wire diameter 5-9 mm required) NOTE: Customer must supply own cable.
WT	Water tight quick-connector installed in housing, pre-wired at Sierra. Allows "plug and play" installation. Must select mating cable from accessories below

Note: Alternate among S0, S1, S2, S3, S4 with Pilot Module display/ interface or Smart-Trak Software

Option 1: Special Cals	
A1	High accuracy calibration, +/- 0.5% of FS at calibration conditions includes 10 point linearization on actual gas (Note: 0.5% accuracy calibration is only possible for Sierra 100 series Smart Trak 2 operating under the following conditions: Flow Range: up to 50 slpm or nlpm (valid from 10 to 100% of the calibrated range); Gases: Air, Nitrogen, Helium, or Argon; . Operating pressure up to 10.3 barg (150 psig); Temperature range: 10°C to 30°C (50°F to 86°F) . Orientation: horizontal. The accuracy is only guaranteed under calibrated conditions and is only valid for a period of 6 months after the date of calibration. Only valid for units up to a operating pressure of 10.3 barg (150 psig) and over the temperature range 10°C to 30°C (50°F to 86°F) in a horizontal position.)
GS	Gas substitution. One or more gases or mixtures may be substituted for 9 of the standard Dial-A-Gas gases. See Application Data Sheet for specifics.

Option 2: Certificates	
MC	Material Certificates--US Mill certs on all wetted flow body parts
CC	Certificate of Conformance

Option 3: O2 Cleaning	
O2C	O2 Cleaning. Includes certification. Product cleaned for O2 service. Inspected with ultra-violet light and double-bagged prior to shipment.



<https://sierrainstruments.com/shop/>

